

SECTION A

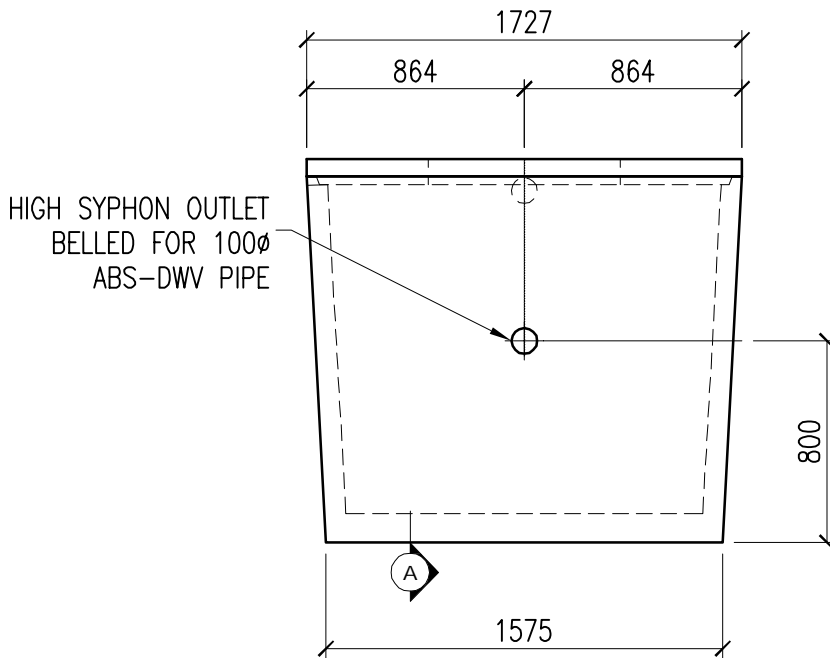

END VIEW

westcon
precast inc.

**M-1500
SEPTIC TANK**

CONCRETE	RELEASE 15 MPa	28 day 35 MPa	AIR 6-8%	SLUMP 70mm	TYPE 50
TANK	LID		TOTAL		
- kg	- kg		8165 kg		
DATE: JAN. 2016	CODE: 0101		BY: CW		

DWG. NO.
W3-06
Rev. **O**